

# WAVE II, 21.5" HINGE

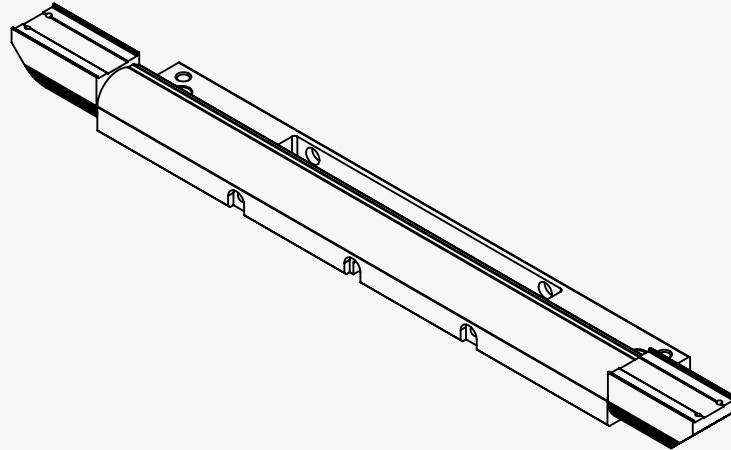

## SUMMARY

<b>ID</b>	30047	<b>NORTH INVENT PART NO</b>	WE215 000 061 (Use for ordering)
<b>COMPANY NAME</b>	North Invent Norway	<b>NORTH INVENT TYPE NO</b>	WE215-01.HIN.01-0061
<b>VAT</b>	987884002VAT	<b>DRAWING REFERENCE</b>	WE215 000 061 DRW
<b>ADDRESS</b>	Sørhauggata 128		
	5527 Haugesund		
	NORWAY		

## REVISION HISTORY

APPROVED	CHECKED	DRAWN	STATUS	DESCRIPTION
2018.10.23 RNO	2018.10.23 RNO	2018.10.23 RNO	Issued for Customer Review	First Revision

2018022201 2019.01.18-B1-General Update

1/4

Specifications subject to changes without prior notice. The contents of this page are property of North Invent Norway AS. All rights herein are reserved to North Invent Norway AS. This document cannot be reproduced without the written permission of the company.

**NORTH INVENT**  
Sørhauggata 128,  
NO-5527 Haugesund, Norway  
Phone: +47 48 84 02 00





# WAVE II, 21.5" HINGE

## TECHNICAL SPECIFICATIONS WE215 000 061

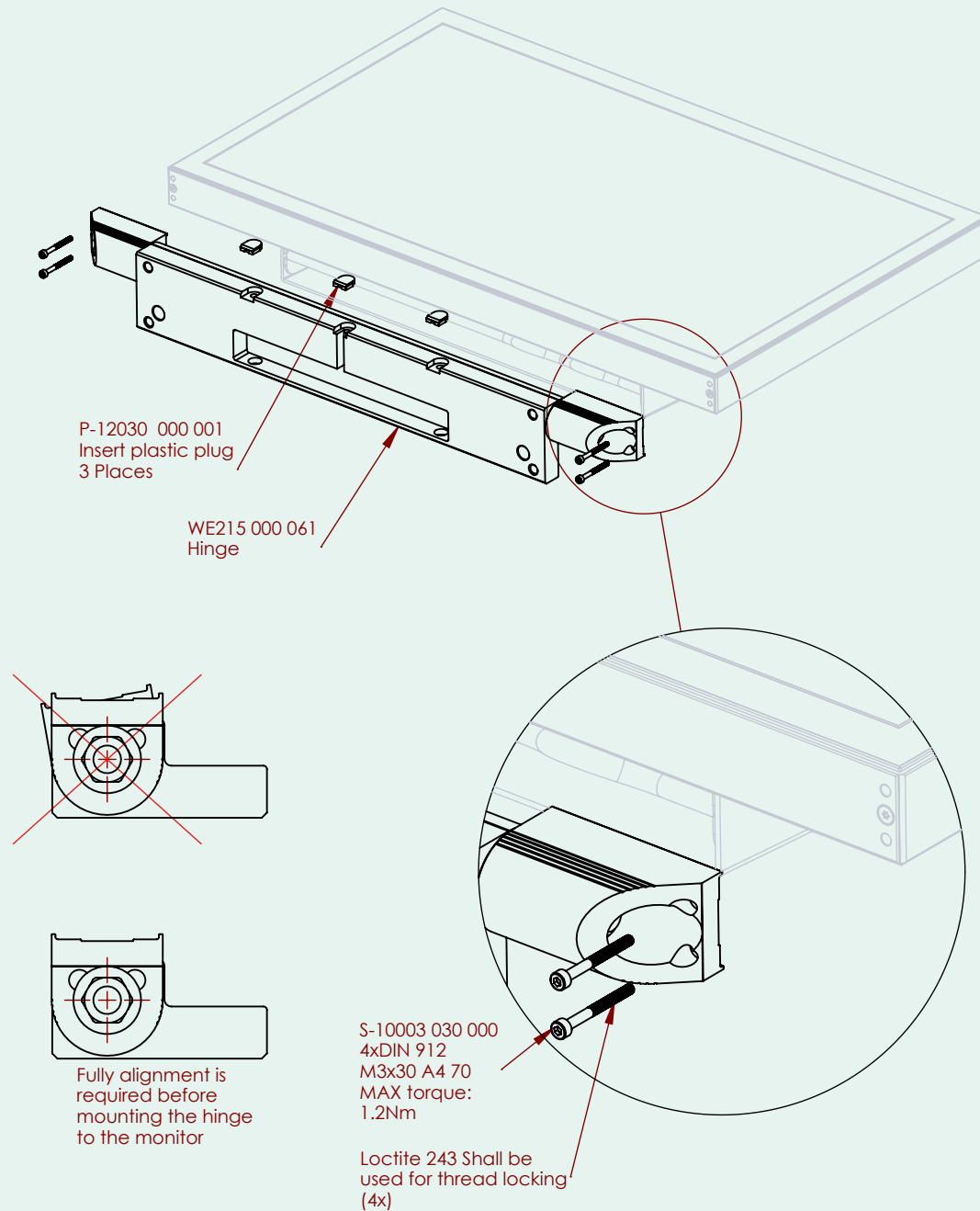

# WAVE II, 21.5" HINGE

## TECHNICAL SPECIFICATIONS WE215 000 061

