

WAVE II, 24" MONITOR

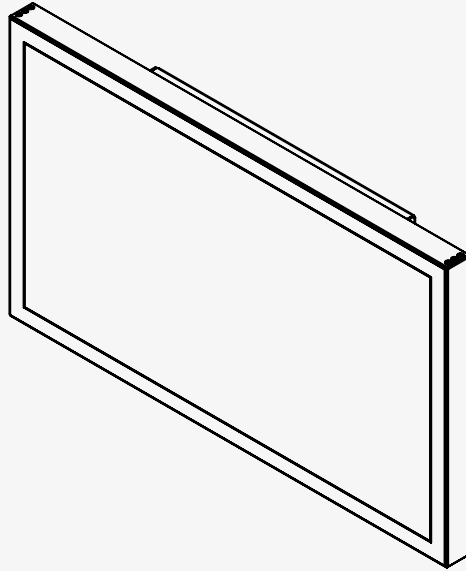

SUMMARY

ID	30047	NORTH INVENT PART NO	WE240 000 115 (Use for ordering)
COMPANY NAME	North Invent Norway	NORTH INVENT TYPE NO	WE240-02.MON.01-0115
VAT	987884002VAT	DRAWING REFERENCE	WE240 000 115 DRW
ADDRESS	Sørhauggata 128		
	5527 Haugesund		
	NORWAY		

REVISION HISTORY

APPROVED	CHECKED	DRAWN	STATUS	DESCRIPTION
2019.02.01 OKJ	2019.02.01 OKJ	2018.06.13 RNO	Issued for Use	General Update
2018.10.11 OKJ	2018.10.11 OKJ	2018.06.13 RNO	Issued for Review	Issued for Use
2018.06.13 RNO	2018.06.13 RNO	2018.06.13 RNO	Issued for Customer Review	First Revision

2018022201 2019.01.18-B1-Packing Information Added

1/4

Specifications subject to changes without prior notice. The contents of this page are property of North Invent Norway AS. All rights herein are reserved to North Invent Norway AS. This document cannot be reproduced without the written permission of the company.

NORTH INVENT
Sørhauggata 128,
NO-5527 Haugesund, Norway
Phone: +47 48 84 02 00



WAVE II, 24" MONITOR

The Wave II Monitors are a series of well-designed, rugged LED displays with full glass front and PCAP multitouch option.

The minimized outer measurements and modular design offer unprecedented configuration and mounting flexibility. Our unique hinge design ensures that table-top or ceiling mounting is equally easy and visually appealing as flush mounting the glass front into a cut-out.

All our monitors are provided with either AC, DC or AC/DC Multipower, whereas our proprietary controllerboard offer extended functionality and connectivity options.

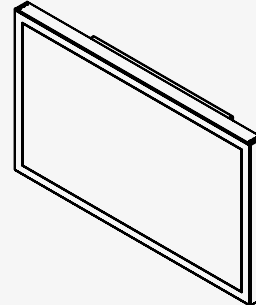

TECHNICAL SPECIFICATIONS WE240 000 115

MATCHING STANDARDS

IEC 60945, IEC 61174 (ECDIS), IEC 60936 (Radar), IEC 62.288 (Navigation), IEC 62.388 (Radar), IEC 60529 (IP), IACS E10, EMC Directive-2014/30/EU, RoHS, REACH, MIL-STD-810 (Shock), MIL-STD-167-1A (Vibration), IEC 61000-6-2 (EMI), IEC 61000-6-4 (EMC), IEC 60068-2-27 (Shock)

DISPLAY SIZE	24.0" - 609.6 mm, Active area 531.36 (W) X 298.89 (H) mm
OVERALL DIMENSIONS	574 (W) x 341 (H) x 78 (D) mm
NET / GROSS WEIGHT	7.5 / 10.6 kg
RESOLUTION	Max 1920 x 1080 pixels (Full HD)
RESPONSE TIME	25 ms
CONTRAST RATIO	5000:1 (typ)
DOT PITCH	0.27675 (H) x 0.27675 (V) mm
LIGHT INTENSITY	1500 cd/m2 (typ)
NUMBERS OF COLOURS	16,7 Millions depending on graphics card
VIEWING ANGLE	±89°
CONTROL KNOBS	NO (Controllable by standard mouse interface)
SUPPLY VOLTAGE	90-264 VAC (IEC Inlet)
POWER CONSUMPTION	Approx. 66W
COLOUR	RAL 9005 Fine Structure
ENCLOSURE PROTECTION	IP 42 (From Front)
GLASS TYPE	3.3mm Tempered, Anti Reflective Conturan®
INPUT/ CONTROL INPUT	DVI-I (Analogue and Digital), Display port, DDC/CI (DVI & DP), RS 422/485, 2 x USB 2.0, Micro SD, USB Type B (Touch Only), 2 x Ethernet, HMI (15p D-Sub), RS 232 (9p D-Sub)
OPERATING / STORAGE TEMPERATURE	-15/+70° C, -15/+70° C (+5/+158° F, +5/+158° F)
BACKLIGHT LIFE	Typ 50.000 Hours
DIMMING RANGE	0-100%
INCLUDED ACCESSORIES	NO
TOUCH	10 Point PCAP Multitouch
ADDITIONAL FEATURE	Onboard iMX6 CPU

2018101001 2019.01.18-B1-Packing Information Added

2/4

Specifications subject to changes without prior notice. The contents of this page are property of North Invent Norway AS. All rights herein are reserved to North Invent Norway AS. This document cannot be reproduced without the written permission of the company.

NORTH INVENT
Sørhauggata 128,
NO-5527 Haugesund, Norway
Phone: +47 48 84 02 00



WAVE II, 24" MONITOR

TECHNICAL SPECIFICATIONS WE240 000 115

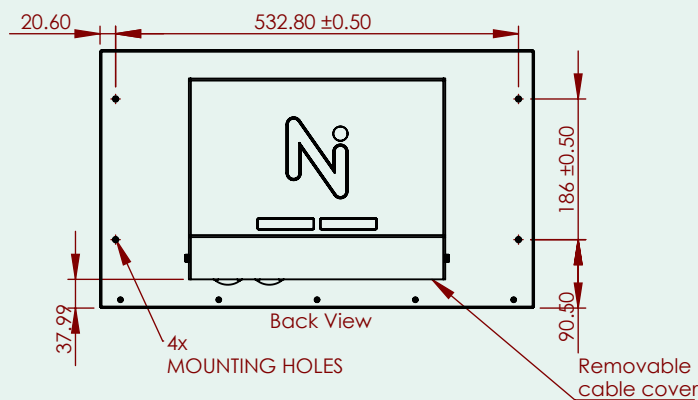
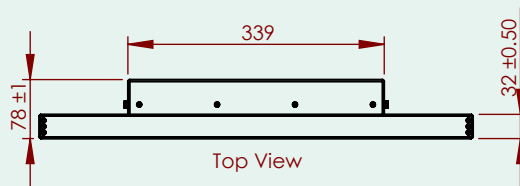
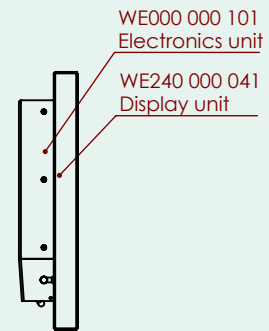
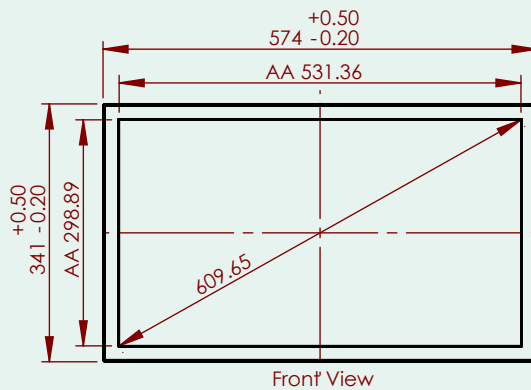

WAVE II, 24" MONITOR

TECHNICAL SPECIFICATIONS WE240 000 115

Included in Part 1 of 1

ITEM NO.	PART NUMBER	DESCRIPTION	QTY.
1	WE999 000 126	1.8m, AC Power Cable	1
2	WE999 000 128	1.8m, Display Port Cable	1
3	WE999 000 130	1.8m, USB A/B Cable	1

