

# WAVE II 21.5" NVIS HIGH BRIGHT

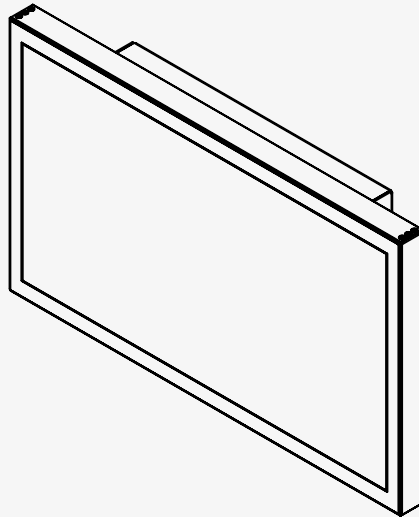

## SUMMARY

<b>ID</b>	30047	<b>NORTH INVENT PART NO</b>	WE215 000 295 (Use for ordering)
<b>COMPANY NAME</b>	North Invent Norway	<b>NORTH INVENT TYPE NO</b>	WE215-02.MON.02-295
<b>VAT</b>	987884002VAT	<b>DRAWING REFERENCE</b>	WE215 000 295 DRW
<b>ADDRESS</b>	Sørhauggata 128		
	5527 Haugesund		
	NORWAY		

## REVISION HISTORY

APPROVED	CHECKED	DRAWN	STATUS	DESCRIPTION
2019.02.01 OKJ	2019.02.01 OKJ	2018.10.18 RNO	Issued for Use	General Update
2018.10.18 RNO	2018.10.18 RNO	2018.10.18 RNO	Issued for Customer Review	First Revision
2020.01.26 OKJ	2020.01.26 OKJ	2020.01.26 OKJ	Issued for Customer Review	NVIS information added

2018022201 2019.01.18-B1-Packing Information Added

1/4

Specifications subject to changes without prior notice. The contents of this page are property of North Invent Norway AS. All rights herein are reserved to North Invent Norway AS. This document cannot be reproduced without the written permission of the company.

**NORTH INVENT**  
Sørhauggata 128,  
NO-5527 Haugesund, Norway  
Phone: +47 48 84 02 00



# WAVE II 21.5" NVIS HIGH BRIGHT

The Wave II Monitors are a series of well-designed, rugged LED displays with full glass front and PCAP multitouch option.

The minimized outer measurements and modular design offer unprecedented configuration and mounting flexibility. Our unique hinge design ensures that table-top or ceiling mounting is equally easy and visually appealing as flush mounting the glass front into a cut-out.

All our monitors are provided with either AC, DC or AC/DC Multipower, whereas our proprietary controllerboard offer extended functionality and connectivity options.

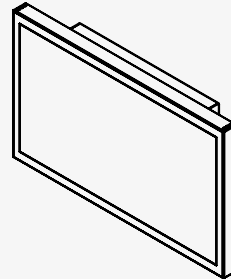

## TECHNICAL SPECIFICATIONS WE215 000 295

### MATCHING STANDARDS

Relevant parts of MIL-STD-461G: CE102, CS101, CS114, CS115, CS116, RE102, RS103, CS118, MIL-STD-810G: 516.6 shock / 528 vibration / temperature), EMC Directive-2014/30/EU, RoHS, REACH. Compliant to MIL-STD-3009 (NVIS Green B).

<b>DISPLAY SIZE</b>	21,5" - 546.1 mm, Active area 476.64 (W) X 268.11 (H) mm
<b>OVERALL DIMENSIONS</b>	513.6 (W) x 310.6 (H) x 78 (D) mm
<b>NET / GROSS WEIGHT</b>	6.6 / 9.7 kg
<b>RESOLUTION</b>	Max 1920 x 1080 pixels (Full HD)
<b>RESPONSE TIME</b>	16 ms
<b>CONTRAST RATIO</b>	5000:1 (typ)
<b>DOT PITCH</b>	0.24825 (H) x 0.24825 (V) mm
<b>LIGHT INTENSITY NORMAL MODE</b>	25 - 1000 cd/m2 (typ)
<b>COLOUR VALUES NVIS MODE</b>	NVIS Green B (u'= 0.131, v'=0.623, tolerance range=0.057, brightness 0.343 cd/m2)
<b>CONTROL KNOBS</b>	Optional / Controllable by standard mouse interface
<b>NVIS MODE SWITCH</b>	HMI unit required to toggle NVIS mode. No confirmation signal provided.
<b>SUPPLY VOLTAGE</b>	18-36 VDC (MIL D38999 connector)
<b>POWER CONSUMPTION</b>	Approx. 70W
<b>COLOUR</b>	RAL 9005 Fine Structure
<b>ENCLOSURE PROTECTION</b>	IP 66 (From front) with panel mounting frame
<b>GLASS TYPE</b>	2.9mm Tempered, Optically Bonded, Anti Reflective Conturan®
<b>INPUT/ CONTROL INPUT</b>	2 x DVI-I, DVI OUT, 2 x Display port, DDC/CI (DVI & DP), 2 x USB 2.0, Micro SD, USB Type A with screw connector (Touch Only), 1 x Ethernet, HMI (15p D-Sub Female), RS 232 (9p D-Sub Female)
<b>OPERATING / STORAGE TEMPERATURE</b>	-15/+70° C, -15/+70° C (+5/+158° F, +5/+158° F)
<b>BACKLIGHT LIFE</b>	Typ 50.000 Hours
<b>VIEWING ANGLE</b>	±89°
<b>INCLUDED ACCESSORIES</b>	NO
<b>TOUCH</b>	10 Point PCAP Multitouch
<b>ADDITIONAL FEATURE</b>	Onboard iMX6 CPU

2018101001 2019.01.18-B1-Packing Information Added

2/4

Specifications subject to changes without prior notice. The contents of this page are property of North Invent Norway AS. All rights herein are reserved to North Invent Norway AS. This document cannot be reproduced without the written permission of the company.

**NORTH INVENT**  
Sørhauggata 128,  
NO-5527 Haugesund, Norway  
Phone: +47 48 84 02 00



# WAVE II 21.5" NVIS HIGH BRIGHT

## TECHNICAL SPECIFICATIONS WE215 000 295

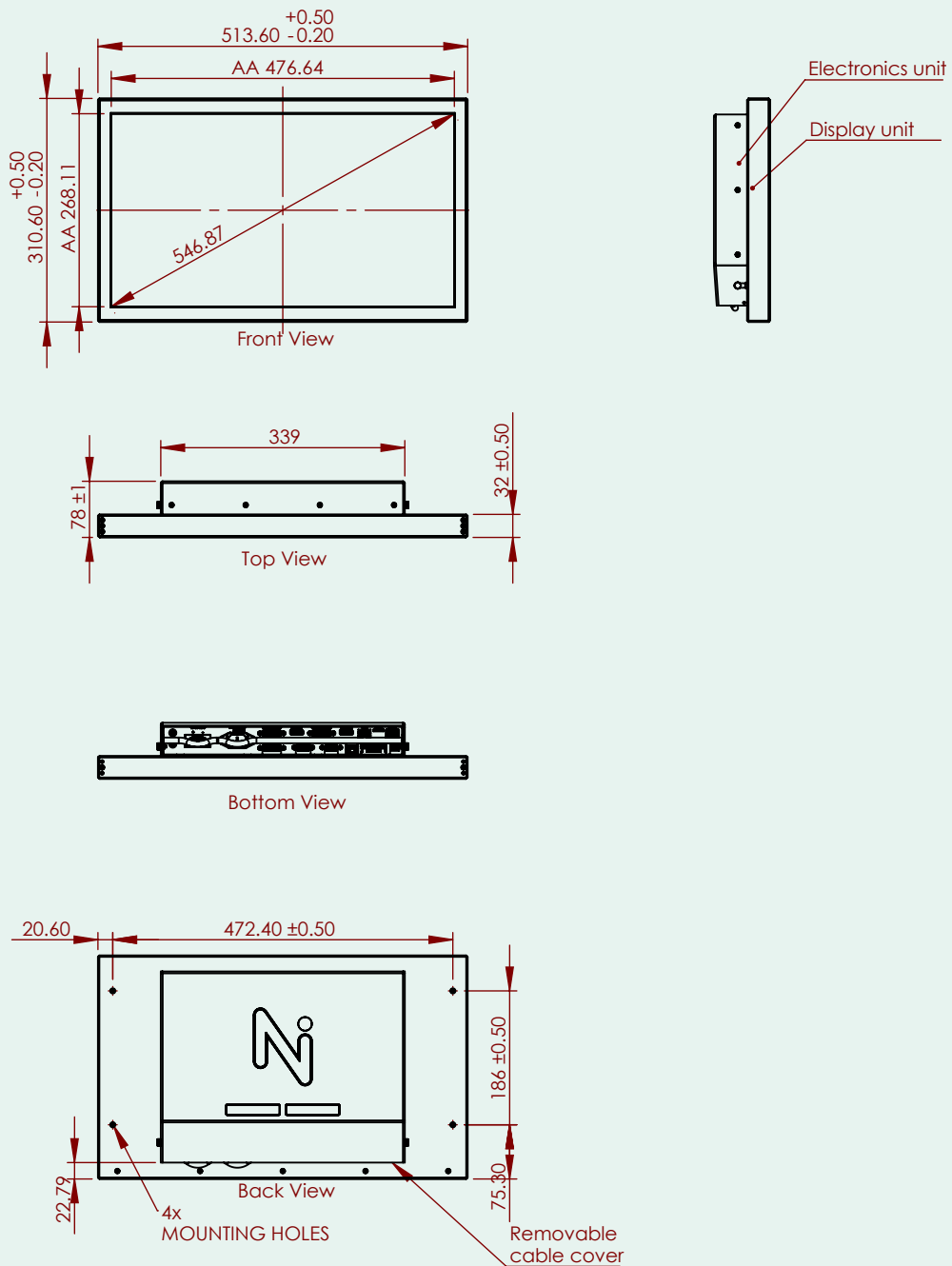

# WAVE II 21.5" NVIS HIGH BRIGHT

## TECHNICAL SPECIFICATIONS WE215 000 295

Included in Part 1 of 1

ITEM NO.	PART NUMBER	DESCRIPTION	QTY.

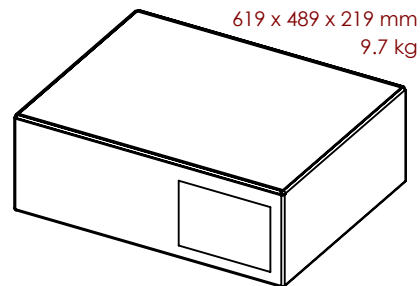
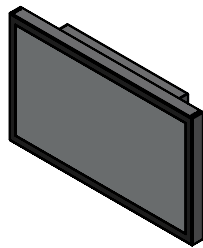

Part 1 of 1  
619 x 489 x 219 mm  
9.7 kg